



The Standard



A MASTER'S GUIDE TO:

SHIPS' PIPING 2nd edition

The Standard P&I Club

The Standard P&I Club's loss prevention programme focuses on best practice to avert those claims that are avoidable and that often result from crew error or equipment failure. In its continuing commitment to safety at sea and the prevention of accidents, casualties and pollution, the club issues a variety of publications on safety-related subjects, of which this is one.

For more information about these publications, please contact the Standard Club or visit www.standard-club.com

The Standard



Author

Eric Murdoch BSc, MSc, CEng, MRINA, MI MarEST
Chief Surveyor
Charles Taylor & Co Limited
Standard House
12-13 Essex Street
London WC2R 3AA
UK
Tel: +44 20 3320 8836
Email: eric.murdoch@ctcplc.com
Web: www.standard-club.com

This Master's Guide to Ships' Piping is one of a series of master's guides that have been revised and updated. In this guide there are significant updates to industry experience and practice regarding engine, cargo and hydraulic piping, and dealing with piping failures by temporary repairs such as clamps and chemical resins. I am grateful to Mark C Ford (Chief Engineer and Standard Club Marine Surveyor) for carrying out this review.

Chris Spencer
Director of Loss Prevention
February 2012

RINA

RINA activities contribute to the wellbeing of society in helping to improve the quality and safety of human life and to preserve the environment for future generations.

RINA states: Our preference is for innovative and authoritative customers who share our objectives of protecting quality and safety, and we establish partnership with them to raise the standard of quality in the relative markets.

The RINA motto is "Together for excellence".



Dott.Ing Francesco Sciacca
Deputy Head of Machinery Section, Marine
Division
RINA SpA
Via Corsica 12
16128 Genoa
Italy
Tel: +39 010 5385651
Email: Francesco.Sciacca@rina.org
Web: www.rina.org

CONTENTS

	PAGE
01 Introduction	02
02 Pipes and P&I claims	03
03 Basic information	04
04 Pipes and ship classification societies	05
05 Ships' piping systems	08
06 Pipe design	19
07 Causes of pipe failure	22
08 Dealing with pipe failure	26
09 Pipe maintenance	27
10 Pipe repair	29
11 Do's and Don'ts	33
12 Appendix I – Mechanical joints in common use	34
13 Appendix II – Pressure test procedure	38

01 INTRODUCTION

Everyone knows about the effect of corrosion on a ship's hull, but few people consider the effect of corrosion on piping. Pipes pose a hidden danger, a danger that is often neglected.

Pipes are silent 'workers', conveying fluids or allowing air to enter or to leave a space and are the means through which many control systems operate. They go unnoticed until pipe failure occurs and a machine stops operating, a space floods or oil is spilled. Pipes penetrate almost every enclosed space, as well as the shell above and below the waterline, and the weather deck. There is no system on a ship that has such enormous potential to cause fire, pollution, flooding or even total loss.

The majority of ships' pipes are constructed of ferrous material, which comes under attack from all forms of corrosion. As a ship ages, so does the piping system. Maintenance is not always easy, as pipes, unlike the hull, are difficult to examine because of their number and inaccessibility. It is practically impossible to maintain them internally and it is sometimes difficult to maintain a pipe's external surface, where most corrosion usually occurs. As a result, pipes can receive minimal maintenance, and pipe failure is often the result. There is a cautionary tale about an operator who was once asked, "when is it necessary to replace a pipe?" His telling reply was, "when it bursts."

The purpose of this guide is to alert ships' crews to the danger of catastrophic loss that can result from pipe failure. Our intention is to raise awareness of redundancy in pipe design and the difficulties involved in the surveying of piping. Pipe failure will be prevented only by a proactive approach to inspection, maintenance and repair.

02 PIPES AND P&I CLAIMS

Failed pipes cause, or contribute to, many serious claims. For example:

- bagged grain on a small bulk carrier was damaged after water escaped from an air pipe running between a ballast tank and the cargo hold. The pipe had a corrosion crack where it connected to the tank top. Water escaped through the crack when the ballast tank was overfilled. The ship was 18 years old, and nothing had been done to protect the pipe from corrosion; not even a lick of paint. Cost – \$120,000. Repairs to the pipe in good time would have cost less than \$50
- bulk fertiliser was damaged when water escaped from a topside ballast tank via a sounding pipe that passed through the tank into the hold below. The pipe was cracked and holed inside the ballast tank. Saltwater ballast drained from the tank into the hold. Cost – \$380,000. Damaged sounding pipes are easily identified during inspections, and repairs are inexpensive
- a cargo ship foundered and four crew members lost their lives. A seawater-cooling pipe in the engine room burst and the engine had to be stopped. The ship was blown onto a lee shore where it broke up on the rocks. Cost – four lives and \$1m in damages. Corroded seawater pipes connecting directly to the shell are often wrongly repaired with a doubler. Doublers should not normally be used to repair shell plating
- a product tanker was gravity ballasting into a segregated tank. The ballast line passed through a cargo tank. When ballast stopped flowing, a corrosion hole in the line allowed oil cargo to escape into the sea through an open valve. Cost – \$975,000
- the main engine of a bulk carrier was seriously damaged when alumina in the cargo hold got into its fuel tank. There was a hole in the air pipe that passed through the cargo hold into the tank. Cost – \$850,000. The pipe had never been properly examined during surveys
- a diesel alternator caught fire after a low-pressure fuel oil pipe burst and sprayed oil onto the exhaust manifold. The pipe had been vibrating, and this movement had caused the pipe's wall to chafe and become thin. The claim cost a new alternator and \$100,000, but the fitting of a pipe support would have cost a mere \$2
- a deck scupper pipe was fitted from the main deck to exit the shell plating, but the piping ran through a fuel oil tank. Because of the age of the pipe and the internal corrosion caused by deck water, a hole opened at the bottom bend of the pipe before it left the ship side plating. The hole was discovered when the ship was detained and fined for oil pollution in a North European port. Cost – \$300,000



^ In service failed pipe

03 BASIC INFORMATION

- the majority of ships' pipes are made of mild steel
- flow rate, viscosity and pressure of the fluid being carried determine a pipe's diameter
- pipes in areas of a ship where there is a risk of gas explosion are earthed, because flow can build up a static electricity charge. Bonding strips are used across flanged joints to maintain conductivity
- pipes that pass through other compartments pose potential subdivision problems, especially open-ended pipes
- pipes, especially those which are open-ended, compromise the integrity of the compartments they pass through
- the seawater circulating in cooling pipes can corrode them over time
- pipes passing through tanks containing certain liquids can be exposed to corrosive attack on both surfaces
- pipes carrying liquefied gas seldom suffer internal corrosion
- visual checks of the external surfaces of a pipe will not always indicate its condition because it could be internally corroded and have reduced wall thickness
- most erosion and consequent internal thinning happens where the pipe changes direction, commonly at elbows and T-sections
- liquid flowing quickly will be turbulent as a result of fluid separation and cavitation. Flow turbulence in a pipe will cause pitting. A pipe with the correct diameter for the application will eliminate most turbulence
- pipes can be joined by butt-welding, with flange connections or mechanical joints. The number of flange connections allowed in the cargo pipes of a chemical tanker is strictly controlled by classification society rules
- good pipe alignment during assembly of a pipe run prevents 'locked-in' stress
- the use of expansion (mechanical) joints, such as dresser-type joints, is restricted to locations where pipes move because of thermal expansion or contraction, or ship bending. Classification society rules prohibit the use of expansion joints for the connection of cargo piping in chemical tankers. The most common expansion joints are compression couplings or slip-on joints
- a pressure test of 1.5 times design pressure is a strength test; a test at the design pressure is a tightness test. Pressure testing can reveal small cracks and pin holes that may not be obvious from a visual examination
- pipes are held in place by supports, hangers or clips that prevent movement from shock loads and vibration. Pipe failure is common when pipes are allowed to vibrate
- pipes carrying flammable substances have as few joints as possible and these are shielded to prevent leaks coming into contact with hot surfaces
- compression joints are not normally fitted on pipes carrying flammable liquids

04 PIPES AND SHIP CLASSIFICATION SOCIETIES

Ship classification societies publish regulations for the design and installation of ship piping systems, defining strength, materials, system requirements (routing), testing procedures and surveying requirements.

Classification society rules require ships' pipes to be inspected during annual, intermediate and renewal surveys.

Annual surveys

Pipes are checked visually. A pressure test is done if there is any doubt as to their integrity, and annually on a tanker's cargo system. Pipes passing through or connecting to the shell plating are subject to particular attention.

Intermediate surveys

The requirements are similar to those applying to annual surveys.

Renewal surveys

Pipes are checked visually and hammer-tested, with some also being pressure-tested. The surveyor will select which pipes are to be pressure-tested. Pipes carrying superheated steam, the fire main and those that are part of a fixed fire extinguishing system should always be tested. Some pipes may be selected for dismantling and internal inspection.

Some piping on deck may be inspected with ultrasonic thickness measurement, to determine the wall thickness. New sections of piping are pressure tested and a representative portion of the welds are tested using non-destructive testing methods. Pipes forming a tanker's cargo system are also pressure tested.

A general outline of the survey requirements for different ship types is shown in Table 1 on page 06.



^ Typical cargo piping

Classification survey requirements

Classification societies have specific requirements for ship’s piping systems that follow the general survey criteria for the rest of the ship. The table below gives an outline of these requirements.

Table 1

Annual survey

All ships	Tankers	Bulk and dry cargo ships
<p>All essential services are generally examined with particular attention to fixed fire extinguishing systems and to fire extinguishing systems which use water. A test under working conditions of the fire main is arranged.</p> <p>The bilge pumping systems are examined and tested.</p>	<p>In addition to the classification requirements for the rest of the ship, the surveyor will complete, as far as is possible, a general examination of all cargo, steam and water ballast piping, including pipes located on deck, in the pump room, cofferdams, pipe tunnels and void spaces.</p> <p>Particular attention is given to:</p> <ul style="list-style-type: none"> • inert gas piping, to verify the absence of corrosion and gas leakage. A test under working conditions is arranged • the crude oil washing system and its fittings • the pump room • piping with high sulphur content oils are prone to rapid corrosion 	<p>In addition to the requirements for the rest of the ship, piping in cargo holds and water ballast tanks are generally examined as far as is possible, including pipes on deck, in void spaces, cofferdams and pipe tunnels.</p>

Intermediate survey

All ships	Tankers	Bulk and dry cargo ships
<p>The scope of intermediate surveys is the same as that of annual surveys.</p>	<p>The annual survey requirements apply. However, depending upon the surveyor’s findings during the general examination, he may require pipes to be dismantled, hydrostatically tested and their wall thickness measured, or all three.</p>	<p>The scope of intermediate surveys is the same as that of annual surveys.</p>

Renewal survey

All ships	Tankers	Bulk and dry cargo ships
<p>The survey involves extensive examinations and checks to show that all piping systems are in satisfactory condition to allow the ship to operate and for the new period of class to be assigned, provided proper maintenance and required interim surveys are carried out.</p> <p>Machinery and all piping systems used for essential services are examined and tested under working conditions, as considered necessary by the surveyor.</p> <p>Steam pipes are especially examined. Superheated steam pipes with a steam temperature exceeding 450°C require additional tests.</p> <p>In addition to the annual and intermediate survey requirements, fixed fire-fighting equipment is tested under working conditions, including relevant gas bottles, which are hydrostatically tested.</p> <p>Compressed air pipes are removed for internal examination and are subjected to a hydrostatic test.</p> <p>Piping systems for fuel or lubricating oil are carefully examined.</p>	<p>All piping systems in cargo tanks, saltwater ballast tanks, double-bottom tanks, pump rooms, pipe tunnels and cofferdams, including void spaces adjacent to cargo tanks, and pipes that pass through the deck or connect to the shell, are examined and tested under working conditions. The surveyor checks for tightness and seeks to establish whether their condition is satisfactory.</p> <p>In addition to annual and intermediate survey requirements, all machinery used for liquid cargo services is examined, including ventilation pipes, pressure vacuum valves and flame screens.</p> <p>The inert gas systems are tested under working conditions. The systems main components are examined internally.</p> <p>On the basis of the results of these examinations, additional checks may be required, which may include dismantling, hydrostatic tests or thickness measures, or all three of these methods.</p>	<p>All piping systems in cargo holds, saltwater ballast tanks, double-bottom tanks, pipe tunnels, cofferdams and void spaces adjacent to cargo holds, and pipes that pass through the deck or connect to the hull, are examined and tested under working conditions to ensure that they remain tight.</p>

05 SHIPS' PIPING SYSTEMS

Bilge system

The bilge system is used to remove small quantities of fluid that have leaked or condensed into a dry space. The system serves the machinery spaces, cargo holds, cofferdams, voids, stores, tunnels and pump rooms. Each space has its own piping but the pump is likely to be shared.

The capacity of a bilge system is defined by the diameter of the bilge main and pump capacity for the volume of the enclosed space.

In passenger and cargo ships where the engine room provides bilge pumping, the whole ship is the 'enclosed space'. The diameter of the bilge main is:

$$d = 25 + 1.68 \sqrt{L(B+D)}$$

where,

d = internal diameter of bilge main, in millimetres

L = length between the ship's perpendiculars, in metres

B = extreme breadth, in metres

D = moulded depth, in metres

In a tanker with a separate cargo pumping and piping system, the 'enclosed space' is the engine room and the diameter of the bilge main is:

$$d = 35 + 3 \sqrt{L_o(B+D)}$$

where,

L_o = length of the engine room, in metres

Cargo ships are required to have two bilge pumps with non-return valves fitted to prevent back-flow or cross-flow.

The pumping system in a passenger ship must be able to drain water from any dry space when one or more of the ship's other compartments are flooded. However, the system is not required to empty the flooded space. A flooded passenger ship is required to have at least one bilge pump, with its own power supply, available for pumping. Bilge suction must have remotely operated suction valves. The minimum number of pumps required is three or more, depending on the ship's design.

Mud boxes and strum boxes (line filters) are fitted at the ends and in bilge lines to stop debris being drawn into the pipe.

The requirements for bilge systems on ships carrying dangerous goods are basically the same as those for general cargo ships. However, systems drawing fluids from gas-dangerous spaces are kept segregated with their own pumps and pipes, where appropriate, from systems serving gas-safe spaces.

Ballast system

Ballast is taken on to increase a ship's draught, particularly the stern draught, when sailing without cargo. On a dry cargo or passenger ship, the ballast system is commonly operated from the engine room. On a tanker, the entire ballast system is commonly located in the cargo area and is operated from a pump room and cargo control room.

Ballast piping is usually made from ordinary mild steel which corrodes. Some ships have ballast piping manufactured from glass reinforced epoxy (GRE) which does not corrode, but care is needed with clamping arrangements to ensure that the pipe is secure and does not move along its axis; this may cause coupling joints to fail. Spare sections of GRE piping should be carried, along with joining couplings and gaskets.

A ship's size determines the capacity of its ballast system.

Firefighting systems

Piping is used extensively throughout a ship for fire control purposes. The specific features of ships' firefighting equipment are governed by the International Convention for the Safety of Life at Sea (SOLAS). Many SOLAS requirements have been incorporated into classification society rules. They include:

- **Fire main**

Mild steel piping fitted with hydrants for hoses where saltwater is used for manual firefighting. The fire main is designed for a typical working pressure of 10 bar. Pipes in the fire main are affected by corrosion both externally and internally. Pipes are joined with flanged connections.



^ Typical fire main piping

- **Sprinkler systems**

Small-bore pipes kept permanently charged with freshwater at 10 bar pressure. A sprinkler system is arranged to release automatically at temperatures of about 70°C, so the system can react and extinguish a fire. The system uses saltwater after the freshwater. After use, it must be flushed with freshwater to minimise corrosion.



^ Typical sprinkler system piping

Some systems operate at higher pressures and produce a fine high pressure mist or fog. These systems are used in oil purifier compartments and above diesel engines to protect the high fire risk areas in engine rooms. It has been proven that rapid operation of this system can quickly contain and extinguish pressure-fed oil fires.

- **Water spray systems**

Usually small-bore piping, which is dry when not in use. A water spray system is operated manually and looks similar to a sprinkler system.

- **Inert gas system**

Fitted on all tankers over 20,000 dwt and on all tankers with crude oil washing systems. Inert gas piping is usually large diameter low-pressure mild steel, with smaller diameter branch lines. The internal surface of inert gas piping does not usually corrode. The external surface is often painted but will corrode if the paint coating deteriorates. The water wash pipework of an inert gas system is usually lined with a corrosion resistant coating, as the wash water from the inert gas scrubbing tower is highly corrosive.



^ Typical inert gas piping

- **Deck water spray systems**

Fitted on gas tankers, these are prone to rapid corrosion, particularly if not flushed through with freshwater and drained.

- **CO₂ piping**

Relatively small-bore hot-dipped galvanised mild steel piping designed to withstand the surge pressures and low temperatures that occur with the release of CO₂. Main CO₂ lines are designed to withstand the same pressure as that of CO₂ bottles, while distribution lines off the main valve are designed for a lower pressure. Typically, the main line is pressure tested to 200 bar, the design pressure being at least 160 bar. Care must be taken to ensure that the system is fully reinstated after it has been tested.

Incidents have occurred where CO₂ has not been correctly released as a result of maintenance valves being left in the incorrect position and even worse, the crew not understanding the method of activating the CO₂ release system.

CO₂ release instructions must be clear, concise and available at the release station. Only appointed persons should be permitted to release the CO₂. Arrange regular onboard training and instruction exercises.

After maintenance has been carried out on the system by either crew or shore technicians, ensure that the system has been fully reinstated and is ready for use.



^ Typical CO₂ piping

- **High-expansion foam**

Uses foam with an expansion ratio of 900 to 1 in mild steel low-pressure piping. Pressure in the lines ranges from 4 to 5 bar. Foam compound in storage tanks is pumped to a foam generator. The system is required to deliver foam at a rate of one metre of compartment depth per minute.

- **Low expansion foam**

Uses foam with an expansion ratio of 12 to 1 in mild steel low-pressure piping. Typical pressure in low expansion foam piping is 12 bar.

- **Dry powder**

Used mainly for the fixed fire-extinguishing system on the deck of gas carriers and on older chemical tankers. Dry powder is held in tanks and is propelled by nitrogen gas stored in pressure bottles. Dry powder delivery pipes are pressurised to approximately 18 bar.

Pipes carrying fuel oil and flammable liquids

There are two principal types of pipes that carry fuel and they are categorised by the pressure the pipe is designed to withstand. Low-pressure pipes are primarily used to move fuel from a storage tank to a service tank and via feed pump on to injection pumps. High-pressure pipes are used to deliver fuel from an injection pump to an engine combustion chamber.

Ship's fuel is usually stored in double-bottom tanks, deep tanks, side bunker tanks, settling tanks or service tanks. Piping between a service tank and a fuel transfer or booster pump is rated as low pressure. However, between each pumping stage, pressure increases.

It is a mistake to assume that even if a pipe's pressure is relatively low, fuel will not spray from a crack or small hole. A small pin hole in a fuel pipe can atomise leaking fuel even at low pressure, creating a highly volatile mixture of air and fuel.

Low pressure fuel pipes, particularly on diesel engines, should be regularly checked for signs of leakage in way of connections and fretting against other piping or objects. Pipe clamp security should be checked closely.

Pipes from fuel tanks can pass through ballast tanks, and pipes serving ballast tanks can pass through fuel tanks. Because of pollution risks, classification societies have stringent rules restricting the length of any oil pipe passing through a ballast tank; it must be short, have increased wall thickness and stronger flanges and subjected to more frequent inspections and testing during survey.

SOLAS includes requirements for fire safety in engine rooms. In particular, special double-skinned pipes must be used to deliver fuel to engine combustion chambers. These are made of low carbon steel alloys and operate at high pressures between 150 and 900 bar. Double skins are necessary because pipe fracture will cause fuel to spray in a fine aerosol. Fuel will ignite on contact with a hot surface, such as a turbocharger casing or exhaust pipe. The second skin is to guard against direct spraying. The pipe is designed so that fuel will be contained in the annular space between the outer skin and the main pipe, and will drain into a collecting tank fitted with a high-level fuel leakage alarm.

Low-pressure lubricating and fuel oil pipes passing close to a hot surface must be secured against the possibility of oil spraying from a flange. To prevent this danger, the flange is usually taped. In addition, and whenever possible, the pipes are routed clear of hot surfaces. Similarly, to prevent leaking oil falling onto a hot surface, such pipes should never be allowed to run above a hot surface.

Regular thermographic surveys of hot surfaces will identify risk areas that are hot enough to ignite spraying or leaking fuel. Preventive measures to be taken include additional lagging, and spray or drip shields.

Fuel oil transfer pipes are usually of mild steel and may corrode. The calculation for minimum wall thickness includes a small allowance for corrosion. As a pipe ages and corrodes, leakage can occur. Inspection programmes should concentrate on identifying worn or corroded pipes.



^ Typical thermal oil piping

Engine cooling systems

Water carried in pipes is used to cool machinery. The main engine is cooled by two separate but linked systems: an open system in which water is taken from and returned to the sea (sea-to-sea) seawater cooling, and a closed system where freshwater is circulated around an engine casing (freshwater cooling). Freshwater is used to cool machinery directly, whereas seawater is used to cool fresh water passing through a heat exchanger. Many engine room systems also use sea water to cool oil, condense steam and even produce drinking water.

The particular feature of any engine room cooling system is continuous fluid flow. Fluid in motion causes abrasive corrosion and erosion. To reduce the effects of turbulent flows, seawater systems incorporate large diameter mild steel pipes, the ends of which open to the sea through sea chests where gate valves are fitted. If a seawater cooling pipe bursts, both suction and discharge valves will have to be closed to prevent engine room flooding. In order to make sure the valves operate correctly when needed, open and close them at regular, say monthly, intervals. Ensure that all engine room personnel are familiar with the location and isolation of the main sea inlet valves and overboards.

Seawater pipes are usually mild steel, but other materials such as galvanised steel, copper, copper alloys and aluminium bronze (Yorcalbro¹) are also used. Seawater pipes fabricated from Yorcalbro generally have a sacrificial section made from mild steel to ensure that galvanic corrosion attacks only the sacrificial pipe. Sacrificial sections as well as sacrificial anodes are also designed to limit galvanic corrosion action from metallic material other than Yorcalbro. These sections of pipe should be regularly inspected and renewed.

Freshwater cooling pipes are generally made of mild steel. These systems are treated with anti-corrosive chemicals and should be tested regularly using the chemical manufacturer's supplied kits to ensure that the water treatment is always at its most effective. Some freshwater cooling systems may become contaminated with microbes and will require treating with biocide additives which are available from the chemical manufacturers.

Air and sounding pipes

Air pipes allow an enclosed space to 'breathe'. They prevent over- or under-pressure by letting air in or out of the space when liquid is pumped in or out, or when temperature changes cause gases or liquid to expand or contract. Cargo holds are ventilated by air pipes passing through the weather deck and these are fitted with self-closing watertight covers (headers). This is a load line requirement.

Sounding pipes are small-bore mild steel pipes used to allow the measuring equipment to enter a tank or a space. The pipe allows a tape or sounding rod to pass through to the bottom of a tank, hold or space. Deck sounding pipes pass through the weather deck and are fitted with screw-down caps. Sounding pipes for engine room double-bottom tanks are fitted with counterweight self-closing cocks. It is imperative that sounding pipe caps or cocks be kept shut and well maintained. Sounding pipes are a potentially dangerous source of progressive flooding. An engine room can be flooded through an open sounding pipe if a ship's bottom is holed. A cargo hold can be flooded through an open deck sounding pipe when water is washed on deck in heavy weather. Holes in weather deck air pipes also cause hold flooding during heavy weather.

¹ Yorcalbro – 70% copper, 28% zinc and 2% aluminium

Air and sounding pipes are normally constructed of mild steel. Normally these pipes do not come into contact with liquid, either inside or outside. The size of an air pipe serving a tank is determined by comparison of the pipe's cross-section area with that of the pipe that will fill or empty the tank. This calculation, by the designer, is to avoid the risk of over- or under-pressure. Air and sounding pipes that pass through other compartments are a potential source of progressive flooding. It is difficult to inspect air and sounding pipes located inside cargo spaces or ballast tanks. However, the integrity of air pipes for ballast tanks can be checked by overfilling the tanks. Pipes passing through a dry cargo space must be inspected for damage caused by contact with grabs, bulldozers, etc. It is advisable to open and inspect air pipe headers on the exposed weather deck once every five years following the first special survey. This is necessary because corrosion on the inside of an air pipe header will not be noticeable externally. Screw-down caps are fitted to the top of sounding pipes. These caps should never be mislaid or replaced with wooden plugs. To extend the life of air pipe headers, they should be galvanised. The self-closing cocks on engine room sounding pipes should never be tied open.

Cargo piping

Cargo piping in oil tankers may be of stainless steel, but is commonly of mild steel. The piping is protected from rusting by external painting. Most large oil tankers have a ring main system that allows increased operational flexibility but with the penalty of reduced segregation. Tankers fitted with deep-well pumps in cargo tanks have dedicated piping. Each tank will have its own pump, pipe and cargo manifold. Stainless steel piping is largely used on chemical tankers, invariably on those with stainless steel tanks for carrying corrosive chemicals. On chemical tankers, cargo pipes must be joined by welding. Flanged connections are allowed on oil tankers, and on chemical tankers at valve connections and for fitting portable spool pieces, which are removable short lengths of pipe used for segregation of piping. Regular pressure-testing of cargo pipes is essential to detect weak points before they fail.

Cargo piping in LNG and LPG carriers conveys liquefied gas at very low temperatures. These pipes are constructed from special austenitic stainless steel able to withstand very low temperatures.

Expansion loops or bellows are fitted to compensate for thermal expansion or contraction and for the flexing of the ship. Pipe joints are kept to a minimum. The piping system, including bellows, is normally welded but with sufficient flanges to allow for maintenance and removal of equipment.

Piping systems outside the cargo tanks are insulated with two layers of rigid self extinguishing polyurethane foam or the equivalent. The insulation is covered with a tough water- and vapour-tight barrier, such as polyester resin reinforced with glass cloth.

Classification societies usually require 100% radiographic testing of butt welds.

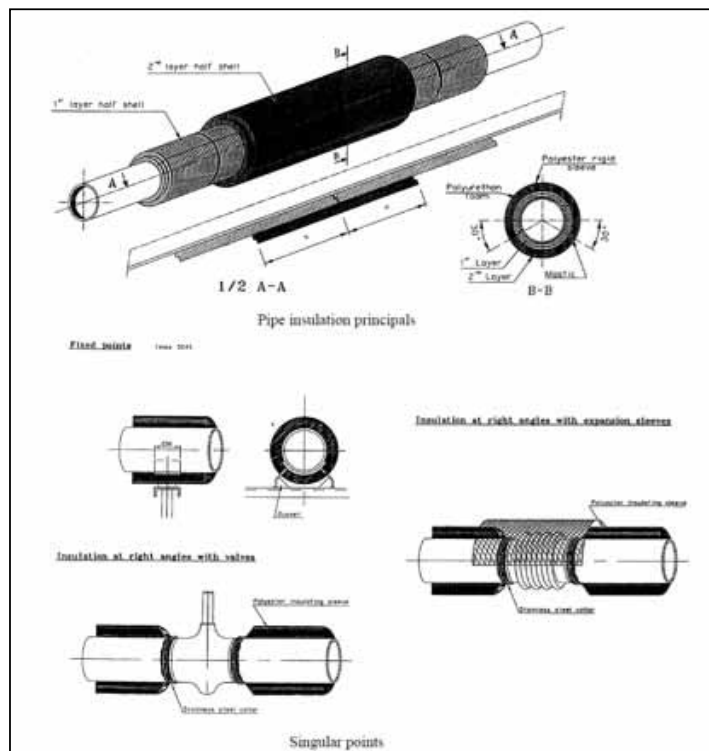

Hydraulic piping systems

Hydraulic pipes are high-pressure pipes. These are used for:

- manoeuvring the steering gear
- actuating controllable pitch propellers and thrusters
- control of watertight doors and valves
- lifting appliances and deck equipment
- opening stern, bow or side doors
- moving mobile ramps for hatch covers
- driving cargo and ballast pumps
- minor shipboard utilities

It is a requirement that hydraulic systems for steering, pitch control and watertight doors have dedicated piping and pumps.

Hydraulic pipes operate at very high pressure. Pipes are weakened because of damage, chafe and fretting, or corrosion. They can burst, allowing hydraulic fluid to spray in a highly flammable, atomised oil mist. As a result, hydraulic equipment and pipework must be kept clear of hot surfaces. Alternatively, hot surfaces must be protected by spray shields.

It is important to prevent external corrosion of hydraulic piping located on deck. A high standard of cleanliness is necessary when working with, or replacing, hydraulic piping. Check the systems regularly for leaks, corrosion or mechanical damage. If a leakage occurs during equipment operation, ensure personnel stay well clear. High pressure oil can penetrate the skin and lead to blood poisoning. Always ensure that pollution prevention procedures are followed.

Use only good-quality and clean hydraulic fluid.

Steam piping systems

Steam is used for indirectly heating oils, water and air. It is also used as a scavenge fire-fighting medium on some slow speed engines. The steel piping that carries the steam must be of seamless construction and joined by flanges with suitable steam-resistant gasket materials. Any welding that is carried out on a steam pipe must be done by a certified welder. Ship's staff should never carry out any welding on a steam pipe. Temporary repairs may be undertaken, but only after a risk assessment and permission from the owner has been obtained. Emergency temporary repair may include a welded patch or a bolted on clamp with steam gasket material providing the seal, but extreme care should be taken around the repair and the area roped off to prevent personnel access. The pipe must be renewed at the next port of call. Tapered plugs should never be used to plug a leak in a steam pipe, as shown below.



^ Temporary wooden plug in steam line, which is HIGHLY DANGEROUS

SHIPS' PIPING SYSTEMS

Insulation must be fitted around steam piping to lower surface temperature below 220°C, to reduce the risk of fire in machinery spaces.

Every steam pipe and every connecting fitting through which steam passes must be designed, constructed and installed to withstand the maximum working stresses to which it may be subjected. Means shall be provided for draining every steam pipe in which dangerous water hammer action might otherwise occur. If a steam pipe or fitting can receive steam from any source at a higher pressure than that for which it is designed, a suitable reducing valve, relief valve and pressure gauge must be fitted.

There have been many accidents resulting in serious injury or death from working on or near steam pipework. Always ensure that the steam line is completely vented with double valve isolation or blank flange before opening a pipe. Always wear the appropriate personal protective equipment (PPE) when opening the pipe, as even when vented, scalding water may still be present in the line. Always carry out a risk assessment and ensure a permit to work is issued. Valve isolation and venting must be cross-checked by another senior engineer.



^ Typical steam piping

06 PIPE DESIGN

Classification societies publish rules for design and fabrication of ship's piping. The rules consider how the pipe will be used, the fluid conveyed, materials for construction, and welding and test procedures. Ship's piping is grouped into three categories, each of which has different technical requirements.

Class I pipes have to comply with the most stringent rules. They include fuel oil pipes operating above 16 bar pressure or above 150°C, and steam pipes operating above 16 bar or where the temperature exceeds 300°C.

Class II pipes are subject to more moderate rule requirements.

Class III pipes have the lowest requirements. They include fuel pipes that operate at or below 7 bar pressure and 60°C.

During design of piping systems, fluid temperature, pressure and the type of fluid conveyed have to be considered.

Materials

Most pipes are made of mild steel. But pipes that carry dangerous chemicals or particularly corrosive fluids are manufactured from stainless steel. Some chemicals can be carried only in stainless steel cargo tanks and pipes. Some small seawater pipes are copper. Glass reinforced epoxy (GRE) is often used for ballast and brine pipes. Sanitary piping may be made from plastic, using plastic welded joints. The use of plastic pipes elsewhere in a system is restricted because of the requirement to pass a standard test for fire-resistance. It is not usual for plastic pipes to be constructed in a way that will enable them to pass the most stringent, level 1, fire test.

There are three levels of fire endurance test. In each case, the procedure is the same, the difference being the duration of the test and the presence, or otherwise, of fluid inside the pipe. At level 1 testing, the endurance period is one hour with a dry pipe. It is 30 minutes with a dry pipe at level 2 and 30 minutes with a wet pipe at level 3. Passing the level 1 fire test is the highest standard: if plastic pipes are to be used, the fire-resistance rating and classification society rule requirements must be checked first.

Pipe dimensions

The required diameter of a pipe depends on the minimum cross-section area necessary to allow passage of a fluid of given viscosity at a given velocity. A pipe's wall thickness depends on the pressure, the temperature of the fluid conveyed and construction materials. Pipes that operate at high pressure, such as hydraulic pipes, have thick walls, while pipes that operate at low pressure, such as ballast water pipes, can be designed to classification society 'minimum thickness'. Pipes that connect direct to the ship's shell have thicker walls. (See Table 2 on page 20).

During design calculations, an allowance for corrosion is factored into the wall thickness. However, the calculated wall thickness can never be less than rule minimum thickness. It is a mistake to believe that the corrosion allowance is enough to prevent failure from uniform corrosion before the pipe is 'design life-expired'.

Pipes passing through tanks must have thicker walls. An allowance for corrosion is added to the pipe's wall thickness to allow for possible external and internal corrosion. The allowance for corrosion is effectively doubled. (See Table 3 on page 23).

Minimum wall thickness for steel pipes

The graph shows the classification society required minimum wall thickness for low-pressure steel pipes.

Table 2

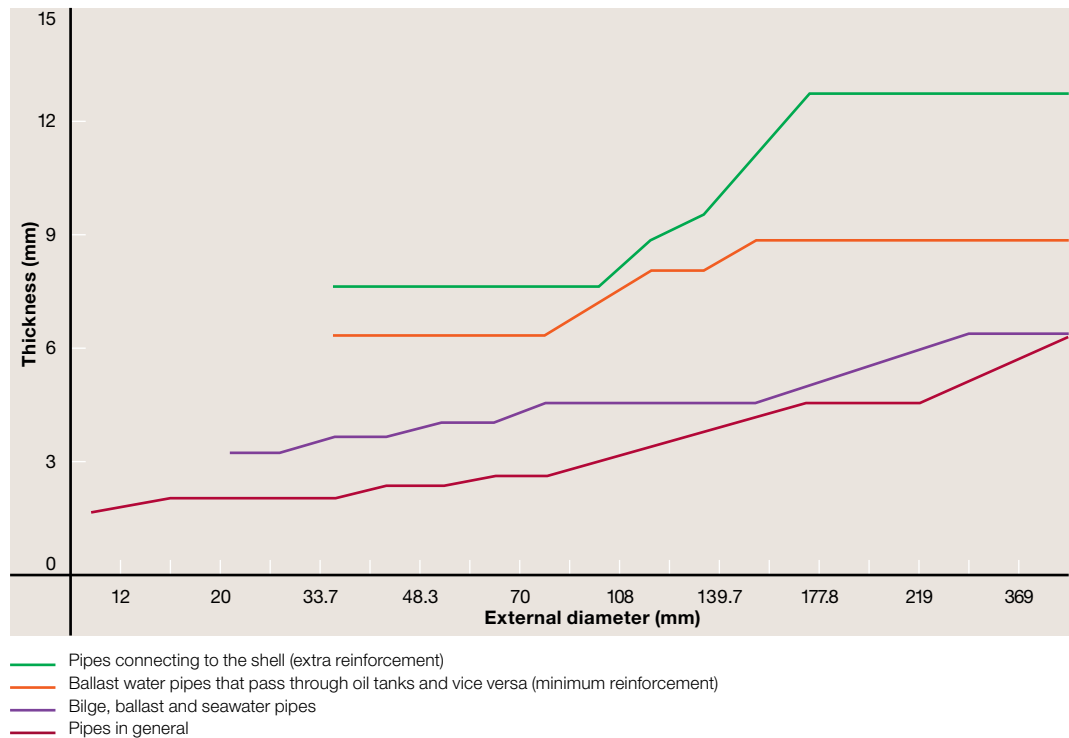

Connection to pumps

Pipes are connected to pumps by flanges. Flanges are a potential weak point in a piping system. Occasionally, and to provide the correct pressure from a pump, a calibration orifice is fitted in the delivery piping. This can result in turbulent fluid flow and cause abrasive corrosion or erosion. Welded flanges are prone to accelerated corrosion in the weld metal or in the heat-affected zone. Pipes in wet areas where corrosion is likely need to be examined at regular intervals

Pipe joints

The preferred method for connecting two lengths of steel pipe, whether a straight, elbow or T-joint, is with a flange. With the possible exception of small-bore pipes in low-pressure systems, pipes are not normally connected by threaded joints. Mechanical, expansion or sliding joints are fitted in longitudinal pipes to allow the pipe to move when a ship bends and flexes, or to cater for thermal expansion. Expansion joints are not fitted where there is regularly high stress, nor are they used inside cargo holds or tanks. Expansion joints should never be used as a permanent connection for corroded pipes after a temporary repair.

Classification society rules define which piping systems to use and the positions in which expansion joints can be fitted. Only approved expansion joints are allowed.

Clips and supports

Clips and supports are used to hold pipes in position and to prevent movement or vibration. A vibrating pipe can 'work harden' and fail. Pipes can fracture when there is insufficient support.

There are no hard and fast rules about the number of clips required in a length of pipe as this will depend on the pipe's diameter, length, position and the density of fluid conveyed. The contact area at the surface of the pipe requires protection. Failures often occur as a result of mechanical wear when the clip loosens or a clip supporting weld fractures, allowing the pipe to move. Inspection procedures must be designed to ensure that all clips are checked regularly, including those hidden from sight behind insulation or under engine room floor plates. Special attention should be paid to clips in concealed places.

Valves

Valves are fitted to isolate sections of pipe and will typically be found at suction points, crossovers, feed lines, delivery lines and where pipes need to be removed. Valves connected to the shell are flanged and made of steel or other ductile material. Grey or nodular cast iron cannot be used for boiler blow-down valves, for valves fitted to fuel oil or lubricating oil tanks, or for shell valves. Shell valves should be tested regularly, on a monthly basis, by opening and closing them and lubricating the valve spindle depending on the design of the spindle sealing. Marking valve handles with high-visibility paint will help with identification during an emergency.

Cast iron valves have a service life shorter than those made from cast steel. Consequently, they need careful examination during a special survey.

07 CAUSES OF PIPE FAILURE

Pipes have a hard life: they carry abrasive and corrosive fluids; they are exposed to atmospheric corrosion and to general wear and tear; they sometimes operate at extremely high and low temperatures. The most common cause of pipe failure is corrosion-induced weakness.

Pipes corrode internally and externally. Internally, they may be affected by erosion, uniform and abrasive corrosion, fatigue and galvanic action. Externally, corrosion is caused mainly by atmospheric conditions, but pipes can corrode locally where liquids drip onto them or erode where clamps have loosened and fretting occurs. Always look for early signs of fretting on piping around clamp fixings by checking for rust or black dust.

Uniform corrosion

Uniform corrosion is the most common form of attack on metal, and its aggressiveness depends on relative humidity, temperature, oxygen content and salt content. It is widespread in pipes carrying saltwater. Pipes on deck, in locations prone to wetting, in bilges and in ballast tanks, as well as pipe supports are at risk of uniform corrosion.

It is a good policy to replace a pipe when the corrosion measured is equal to or greater than the design allowance.

Accelerated corrosion can occur in steam piping fitted to the decks of tankers. If pipes are insulated, and the insulation gets wet and stays wet, corrosion is accelerated. Table 3 on page 23 shows the optimum corrosion allowances for various types of pipe.



^ Corroded piping

Pitting corrosion

Pitting corrosion is defined as the localised breakdown of the inert surface layer that protects metal against the formation of cavities or small diameter holes. Such corrosion can occur in mild steel and stainless steel. It has a random pattern, as pits are formed from the breakdown of a pipe's protective film. Pitting happens more readily in a stagnant environment. The Oil Companies International Marine Forum's Guidance Manual for the Inspection and Condition Assessment of Tanker Structures contains pitting intensity diagrams for plates, and these can be used to categorise the extent of pitting. As a general rule, any badly pitted pipe needs replacing.

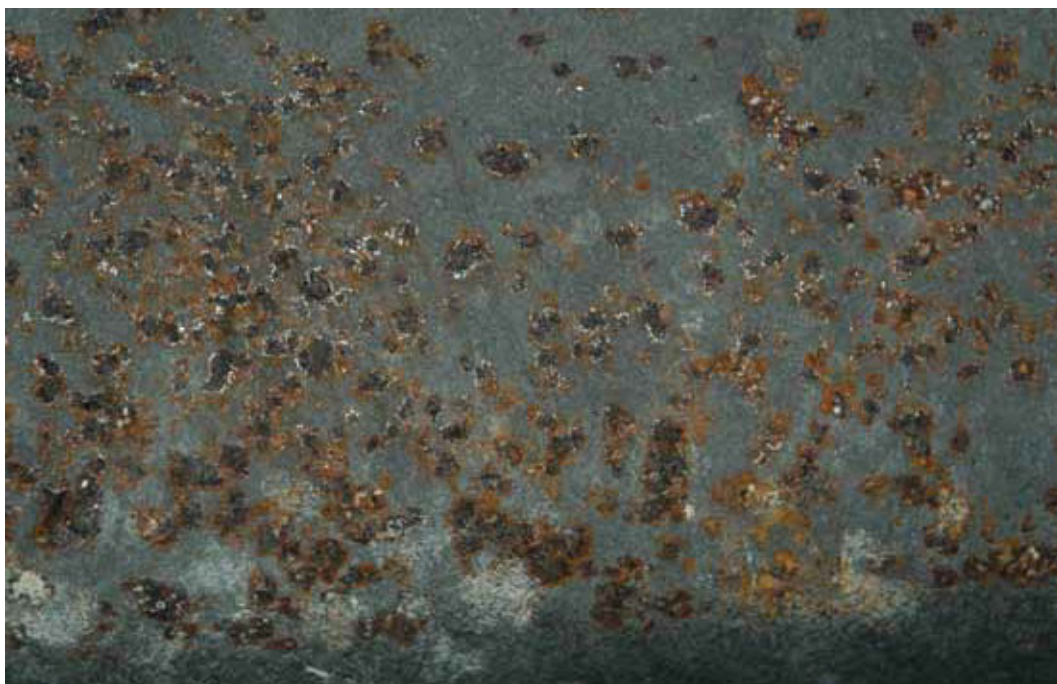

^ Typical pitting corrosion

Abrasion and erosion

Abrasion and erosion are the wearing away of material by a flow of fluid. Material that has been abrasively corroded or eroded looks pitted. To determine whether material has been lost by either abrasion or erosion, it is necessary to examine the processes involved in both.

Table 3

Corrosion allowance for steel pipes in mm

Superheated steam systems	0.3
Saturated steam systems	0.8
Steam coil systems in cargo tanks	2
Feedwater for boilers in open circuit systems	1.5
Feedwater for boilers in closed circuit systems	0.5
Blow-down (for boilers) systems	1.5
Compressed air systems	1
Hydraulic oil systems	0.3
Lubricating oil systems	0.3
Fuel oil systems	1
Cargo systems for oil tankers	2
Refrigeration plants	0.3
Freshwater systems	0.8
Seawater systems in general	3

CAUSES OF PIPE FAILURE

Abrasion happens when solid particles, such as sand, suspended in a fluid flow, scour a pipe. It is therefore a mechanical process. If the oxidised surface protecting a pipe's base metal suffers abrasion from such flows, uniform corrosion or pitting can result. The main characteristic of abrasion is cracking in the direction of flow. Filters are fitted in ballast and bilge lines to prevent debris from being sucked into a pipe. A slower than expected pumping rate may indicate that filters are clogged and that they need cleaning. Worn or damaged filters must be replaced.

Erosion is caused when turbulent fluid flows hit a pipe's inner surface; it is most common at points where a pipe bends and at elbows where fluid flow changes direction, or where an orifice, valve, welded joint or any other blockage impinges on fluid flow to cause turbulence. Prevention of turbulence is the key to prevention of erosion. The use of larger diameter pipes, together with a reduced pumping rate, can eliminate flow turbulence and erosion.

Fatigue damage

Fatigue damage is the rapid deterioration of metal, resulting in cracking and collapse. It is caused by cyclical mechanical stress, such as when pipes are connected to machinery or other pipes that vibrate. Pipe compensators (bellows) are normally used in these areas to reduce such effects.



^ Exhaust pipe compensators (bellows)

Galvanic corrosion

Galvanic corrosion is the electro-chemical process between different metals. It is most common where pipes connect to equipment made from a different metal, and where there is an electrically conductive path between the metals through an electrolyte. Some piping systems may have sacrificial pipe sections to concentrate the galvanic corrosion in one place. They provide corrosion protection to the remainder of the system. Sacrificial pipe sections should be routinely inspected, and renewed when required.

Graphitic corrosion

Cast iron pipes and fittings are affected by graphitic corrosion that is most commonly found at bends and elbows, locations where boundary layers cause water to flow at different velocities, and where water accumulates. Graphitic corrosion attacks the inside of a pipe by oxidation and leaching of iron. It results in the formation of rust supported by graphitic flakes. The process occurs over a period and, if the pipe is not replaced, will continue until the pipe weakens and eventually fails, usually catastrophically.

The risk of failure through graphitic corrosion can be reduced by:

- identifying every cast iron pipe or fitting that has a connection to the sea
- using ultrasonic equipment to measure the wall thickness of pipes over 10 years old; this should be done annually
- during a docking survey, removing for internal examination all iron pipes over 10 years old that are located in high-risk areas likely to be affected by graphitic corrosion, such as elbows, where flow velocity changes and where water can accumulate

Water hammer

Water hammer can affect any pipe but is most common in steam pipes. It is a problem in pipes where internal condensation occurs. Water hammers are impulse pressures that happen when steam enters a cold pipe containing a small amount of water. The resulting stresses, along with possible rapid expansion, can cause pipe joints to fail. Prevent water hammer by draining fluid from pipes before injecting steam gradually.

Steam systems are most prone to damage by water hammer because they operate at high temperature and pressure, and because condensed steam will remain in them, unless regularly drained.

Steam heating coils on tankers are particularly susceptible to damage by water hammer.

Pipe alignment

Irregular stress affects pipes that are forced into alignment. If they have been weakened by corrosion, or stresses caused by thermal expansion or impulse loading, the pipes will fail. Forcing pipes into alignment is bad engineering practice. Failures are most likely at flange connections or valves.

Low temperature

Very low temperatures cause water to freeze and expand in un-insulated pipes. In cold conditions, high-viscosity or solidifying substances will become difficult to pump because of their tendency to constrict the flow in pipes. Care must be taken to avoid over-pressurising the pipe in an attempt to increase flow. It may be necessary to add anti-freeze to a pipe system, or to arrange external heating, if conditions get really cold. In extremely cold regions, drain deck water systems which are not in use to prevent damage.

Expansion

Metallic pipes expand and contract as the temperature changes. A ship's movement will cause them to stretch and bend, and unless these stresses are absorbed by an expansion joint or pipe compensator, pipes can fail. Bulkheads pierced by pipes present special problems. The bulkhead's strength has to be maintained and the stresses resulting from a pipe's movement have to be absorbed. If the bulkhead forms part of a fire zone, insulation has to be repaired or replaced to ensure that fire integrity is not compromised.

08 DEALING WITH PIPE FAILURE

It is not always practicable to examine every pipe on a ship, which means that pipe failure is always a possibility.

If a pipe fails, the following action should be taken:

- switch off relevant pumps; isolate the affected section of pipe by closing valves or by fitting blank flanges
- investigate the source of the leakage and make a temporary repair by binding or clamping. At the first opportunity, have the pipe repaired or renewed by a specialist repair shop
- avoid getting electrical equipment wet. If electrical equipment is wet, take care to avoid electric shock hazards. Switch off electrical equipment
- if there is leakage from a fuel, lubricating or hydraulic pipe, use absorbent material to soak up the loose oil. Oil is both a safety and a pollution hazard. Fuel spraying from a fractured pipe into an enclosed space, or onto a hot surface, is an extremely dangerous fire hazard
- if there is leakage from a fractured steam pipe, evacuate the boiler area to avoid the risk of personal injury. This type of leakage can be extremely hazardous, especially if the steam is superheated, because superheated steam is invisible and difficult to detect. Test for a steam leak with a piece of cloth at the end of a pole, observing whether the cloth flutters in the jet stream. Superheated steam leaks are very noisy. Caution must be taken if there is extreme noise in a steam plant, for this indicates a superheated steam leak
- if ballast piping on an oil tanker fails, exercise caution before pumping ballast into the sea because the ballast could be contaminated with oil, Check the surface of segregated ballast for oil before beginning discharge. Oil discharge monitoring equipment is fitted on a tanker to prevent oil-contaminated ballast or oil-contaminated wash water being discharged into the sea beyond the limits laid down in MARPOL Annex I
- exercise extreme care after failure of a cargo or fuel pipe as pipes may pass through a ballast tank. The discharge of dirty ballast to the sea is prohibited except in accordance with MARPOL 73/78 Annex I
- if fuel becomes contaminated with water, seek advice from a recognised fuel oil specialist before using the fuel
- if cargo piping failure happens on a gas carrier or on a chemical tanker, take measures to avoid vapour inhalation or skin contact. A significant escape of flammable gas from cargo piping presents an extreme explosion hazard, especially if the gas gets into the accommodation. If liquid gas leaks and pools onto deck plating, it will induce super cold shock stress cracking that may result in catastrophic failure
- failure of a pipe that connects directly to the ship's shell can result in serious flooding, especially if the connection is located below the waterline or in the engine room, because most ships are not able to survive engine room flooding. It is therefore essential to make sure that both suction and discharge valves can be closed, and that they are leak-free. Ensure that emergency bilge suction valves are free and that crew are familiar with emergency bilge valve operating procedures
- any pipe failure on board ship is to be assessed and the companies ISM procedures followed
- class implications – class must be informed if in any doubt with the location of the pipe failure

09 PIPE MAINTENANCE

Unless they are made of non-corrosive material, are galvanised or plastic-coated, the external surfaces of pipes should be painted. Generally, the maintenance of pipes should concentrate on identifying and replacing those that have weakened. It is important to identify failing pipes before leakage occurs; maintenance of piping is as much about procedural checks and pressure tests to locate weak points as it is about actual repair. The following inspection procedures are recommended:

- inspect exposed piping and pipes in wet or damp locations at regular intervals as set down in the ship's maintenance schedule. Look for breakdown of the protective coating. Check for frictional wear at pipe clips and expansion joints
- inspect the inside of pipes where they connect to pumps and refrigeration equipment; this may require the removal of a length of pipe. Look for cracks caused by erosion
- inspect copper pipes for signs of green colouring, which indicates corrosion
- check bends and supports for fatigue corrosion that can occur when piping is subject to vibration. If a pipe does vibrate, fit additional clips or supports
- check tie wall thickness along the outer part of a curved pipe that forms an expansion curve. Expansion curves are usually cold bent and have reduced thickness on the outer part of the bend. Erosion inside the pipe can cause accelerated thinning of the outer wall. Measure thickness with an ultrasonic meter
- check a pipe's threaded connection where it is attached to a component made of different material. Look for galvanic corrosion
- check fixed expansion joints (bellows) for deformation. Look for distortion that can occur with overpressure. These joints are designed to withstand twice the pipe's normal working pressure. They are not designed to accommodate pipe misalignment. Deformed bellows must be replaced
- check for localised leakage as this can cause accelerated corrosion. Inspect glands on valves fitted in saltwater ballast lines and seawater cooling pipes. Repair all leaks, irrespective of size
- open and close line valves at scheduled intervals, especially those used infrequently. Pay special attention to valves that connect to the shell
- repair paint coatings. Fit a doubler where the pipe has suffered frictional wear as a result of chafing contact with a support clip or clamp
- measure a pipe's wall thickness and replace it if its corrosion allowance has been reached
- remove lengths of insulation from steam pipes and check for corrosion if the lagging appears damp or a leakage is suspected. Repair or replace corroded pipes. When replacing insulation, refit with an external layer of waterproof material
- look for exterior pitting when checking stainless steel piping, especially if it carries saltwater. This is easily identified by the presence of small rusty points on the pipe's exterior. If these are found, repair with a section of new pipe. A temporary repair can be made by chipping away the rust, cleaning the area of pipe with a stainless steel wire brush and painting it. Pitting is also likely to occur on the pipe's inner surface and its presence can be detected by removing a section of pipe and checking visually. Good quality stainless steel should last a long time unless it is used in seawater applications. It is recommended by class rules that shipowner's should not use austenitic stainless steel for piping that carries saltwater. Austenitic stainless steel has poor tolerance of seawater. Duplex stainless steels are normally the accepted material for marine applications

Duplex stainless steels are typically found in areas like:

- heat exchangers
 - marine applications
 - desalination plants
 - off-shore oil & gas installations
 - chemical & petrochemical plant
-
- co-ordinate visual examinations with pressure tests. Some operators prefer to carry out a pressure test before a visual examination. Pressure tests should be arranged after a pipe has received an impact, even if there is no obvious damage. When carrying out a hydraulic test, which is a pressure test using water, apply a pressure equal to 1.5 times the pipe's working pressure. Before the test, isolate ball valves to avoid accidental damage to valve seals. Always remember to carry out a risk assessment and obtain a permit to work before beginning any pressure test
 - use a pressure test to reveal small cracks, holes, and leakages at flanges or at other connections
 - whenever accelerated corrosion or advanced thinning of a pipe is found, check all such pipes in similar locations as they are also likely to be affected
 - if a particular space needs regular bilge pumping, this indicates leakage. Check the space thoroughly to identify the leak

Details of a standard pressure test are contained in Appendix 2.

10 PIPE REPAIR

Pipes that fail are not normally repaired, they are replaced. If there is a need for local repair, then treat it as a temporary repair.

- temporary repairs can be made by using binding and rubber, cement boxes, rings and clamps, or plastic resin. Wooden plugs in conjunction with binding are occasionally used to plug a holed low-pressure water pipe but must never be used on steam piping
- permanent repairs usually involve the removal and replacement of a length of piping. Welded doublers are not acceptable as a permanent repair. Remember that welding a corrosion-protected pipe will damage the pipe's internal protective coating and cause accelerated corrosion
- a permanent repair may only be done using material approved by the classification society. The society's rules will require the repair to be examined and approved by its surveyor
- after making repairs, do a pressure test and a non-destructive test of any welded connection, using the dye penetration procedure
- after completing any repair, refit pipe supports or clips. Use additional supports if the pipe moves or vibrates
- replace spray shields on pipes that carry flammable liquids, especially if the pipe is located near a hot surface
- replace or renew lagging or cladding that has been removed before repair. Ensure that the risk of burns and fire is minimised
- slag can fall inside pipes joined by welding and cause a blockage or clog valve seats. Flush the pipe before use
- after repairing lubricating oil or hydraulic pipes, seek the equipment maker's advice on the care of oil and filters

Emergency repairs

When a pipe fails in service, the only remedy may be to carry out a temporary, emergency repair to ensure the safety of personnel, the environment and the ship's cargo.

There are numerous products on the market that claim to repair a failed pipe effectively, but it must be stressed that the best method is renewal.

The following are some suggested actions that have proven successful in the past:

Plastic steel – A fast curing, steel-filled epoxy putty for emergency repairs and quick maintenance work. Recognised trade names include Devcon™ and Belzona™.

The manufacturer's advice on surface preparation and application must be strictly followed to ensure effective repair.

Recommended applications

- repair cracks and breaks in equipment, machinery or castings
- patch and rebuild blow holes or pits in castings
- rebuild worn equipment, pump and valve bodies
- restore bearing journals and races



^ Plastic steel before mixing

Fibreglass tape and epoxy resin wrap – A standard resin and hardener used in conjunction with fibre glass reinforcement tape. Recognised trade names include Thistlebond™.

The manufacturer's surface preparation and application must be strictly followed to ensure effective repair.

Recommended application

- fractured pipes
- corroded pipes

Rubber insertion and band clamp – A mechanical device that is fitted over the failed section of pipe. Pipe surface must be adequately prepared to ensure effective sealing of the rubber. Different sizes are available to suit various pipes.



^ Rubber insertion clamp

Another method commonly used to stop a small drip from a pipe is a rubber insertion and a hose clip. This method has long been used for a quick emergency repair.



^ Rubber insertion and hose clip

PIPE REPAIR

Welding of doubler – This method can be used on most types of metal pipes. The welder applying the doubler or patch must be fully familiar with the material being welded and be competent to carry out the repair in a safe and effective way.

Normally the patch applied is much greater than the failed area. This is normally because the material thickness is insufficient in that area, which inhibits a good weld. Sufficient pipe wall thickness is required for an effective welded patch repair.

Either electric or gas welding can be applied depending on the type of material being patched.

All necessary risk assessments must be carried out and a hot work permit obtained. Remember to remove or cover all flammable materials and maintain a fire watch during welding operations and for a period after welding has ceased.

It must be noted that any pipework modifications or additions are to be shown as updates on the ships piping diagrams and if necessary, class approval must be carried out.

As with all defects and repairs on board ship, the company's procedures must be followed. This can be by way of defect reporting as included in the company's ISM system.

11 DO'S AND DON'TS

Do's and don'ts

Always:

- carry out a risk assessment and obtain a permit to work before any work starts on a piping system
- replace pipes that have significant corrosion, that is, when the corrosion allowance has been used up, and check all similar pipes, replacing as necessary
- check its wall thickness regularly as a pipe ages, concentrating on bends, elbows, deck, bulkhead and shell penetrations
- arrange for regular pressure testing at 1.5 times the design pressure. As a minimum, this should be done every two years
- open and close shell valves at regular intervals, and overboard discharges, taking care not to discharge oil accidentally
- refit pipe supports after maintenance and check them for erosion or mechanical damage. If pipes vibrate, fit additional supports
- keep pipes leak-free; paint them to prevent corrosion
- fit spray shields around fuel and other pipes carrying flammable substances close to hot surfaces
- arrange a tightness test, at design pressure, of pipes that have been accidentally hit
- make sure that all blank flanges have been removed on completion of a pressure test
- inspect pipes running near a hot surface on a regular basis
- ensure that insulation is maintained in good condition and is free from oil contamination

Never:

- fit wet lagging around mild steel pipes
- wait until a suspect pipe begins to leak before arranging a repair
- use fire hoses to replace a failed metal pipe, except as an unavoidable emergency repair
- repair with a mismatch of materials, or with material of different thickness in the same piping run
- leave material, equipment or clothing inside a pipe after repair
- use stainless steel pipes in saltwater systems without washing them with freshwater after use. Static seawater will cause pitting in stainless steel
- force pipes into alignment
- use welding to repair an 'in-situ' fuel or lubricating oil pipe

12 APPENDIX I – MECHANICAL JOINTS IN COMMON USE

Grip type (Straub™ coupling)

Provides axial resistance and can be used with pipes under medium pressure.

These joints are usually fitted in ship piping systems made of certain materials, in particular in Yorcalbro and other sea water systems for maintenance purposes, as they enable pipe disconnection without cutting the pipe. They are also used to connect new sections of pipe when repair of small lengths is necessary. They are normally made from stainless steel and have clamp bolts which are tensioned using a torque wrench to prevent over-tensioning. If the bolts are not made from stainless steel, check them regularly for corrosion; failure can cause extensive flooding.



^ Typical grip type coupling

Machined groove type (Victaulic)

These joints are commonly fitted in deck hydraulic systems. They provide axial resistance and can be used with pipes under medium or high pressure. The joint is achieved by using a pre-deformed or machined piece of pipe and an internal rubber seal. The pipe's wall may have a machined groove to enable connection of the joint. This groove reduces the wall thickness and induces a weakness, creating a hidden point susceptible to failure. If the groove is rolled, material is not removed, and the inside of the pipe is deformed by the rolling. This disturbs fluid flow, leading to cavitation and increased erosion.

Slip type

These joints can be used only with pipes under low or medium pressure because sealing is achieved by packing alone. The joints have minimal axial resistance and clamps should be fitted either side of the coupling to resist axial forces attempting to push the joint apart when the pipe is pressurised.



^ Slip type coupling

Swage type

These joints are pre-assembled and cannot be dismantled. They can be used with pipes under medium to high pressure. Special tools are required to assemble and fit the joint. Care must be taken during assembly not to over-tighten the fitting because the sealing ring can cut into the pipe and weaken it.



^ Swage type coupling

Push fit (press type)

These fittings are pre-assembled and cannot be dismantled. They can be used with low to medium pressure pipes. There is an internal seal which achieves joint tightness. These joints are normally used on low pressure domestic freshwater systems. During maintenance, check that the internal sealing ring has not become hard, as this may cause the joint to leak.

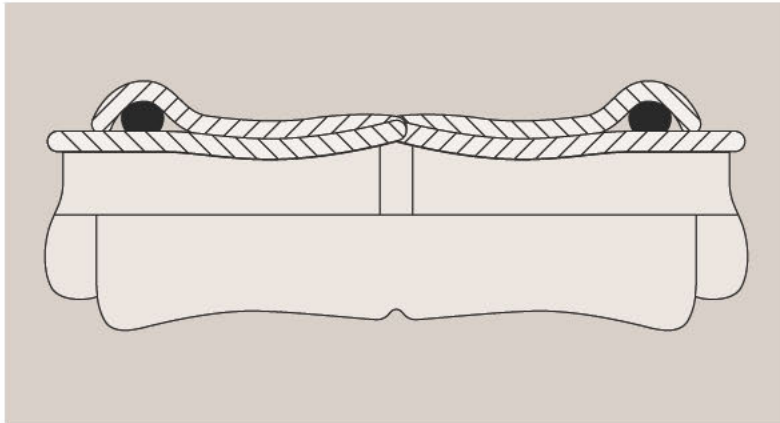

^ Typical push fit (press type) fitting

Byte type/compression joint

Special joints which can be used in high pressure systems. This joint is the most common means of connecting small diameter pipes. The fitting is easily disconnected and reconnected. During assembly, care must be taken to ensure that the sealing olive is not over compressed, as the olive may split or cut the pipe.



^ Compression coupling

Flared joint

Special joints used in high-pressure pipes.

A flared joint is generally used to connect copper pipes in refrigeration systems and to connect tungum® alloy (aluminium, nickel, silicon and brass) tubing in shipboard diving systems. With any form of soft flared joint, care must be taken to use the correct flaring tool to ensure a good seal. Copper and tungum harden with age. This can cause leakage if the pipe is moved or the flare nut over-tightened. Copper gauge lines in fuel and oil systems are prone to this problem. This causes leakage which is difficult to detect.

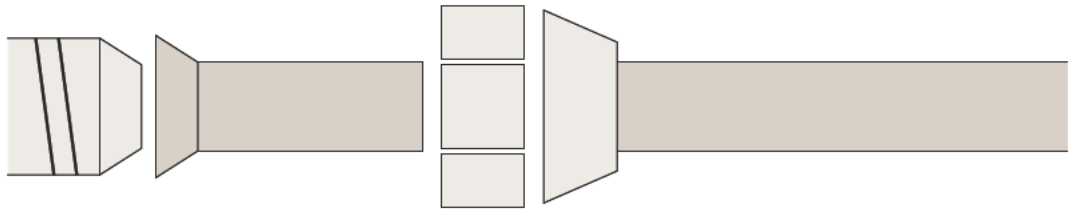

^ Flare nut

13 APPENDIX II – PRESSURE TEST PROCEDURE

A hydraulic pressure test is a straightforward shipboard operation.

Follow these guidelines:

1. obtain the relevant permit to work and carry out a risk assessment before starting work on any pipe
2. isolate the area where piping is to be tested
3. fill piping with water, taking care to eliminate all possible air pockets before raising the pressure
4. increase the pressure in the pipes slowly, making sure to avoid shock loading. Watch out for problems as the pressure increases
5. when the maximum pressure is reached, maintain that pressure for between 15 and 30 minutes
6. monitor the pressure inside the pipe by using a certified manometer. Check that a reduction in pressure does not occur apart from that arising from thermal variations. In large piping installations, a chart recorder with temperature compensation may be used to record the pressure test for verification and certification purposes
7. even if there is no significant reduction in pressure, check the pipe visually for small leaks. Before performing this check and as a safety precaution, it is advisable to reduce slightly the pressure in the pipe

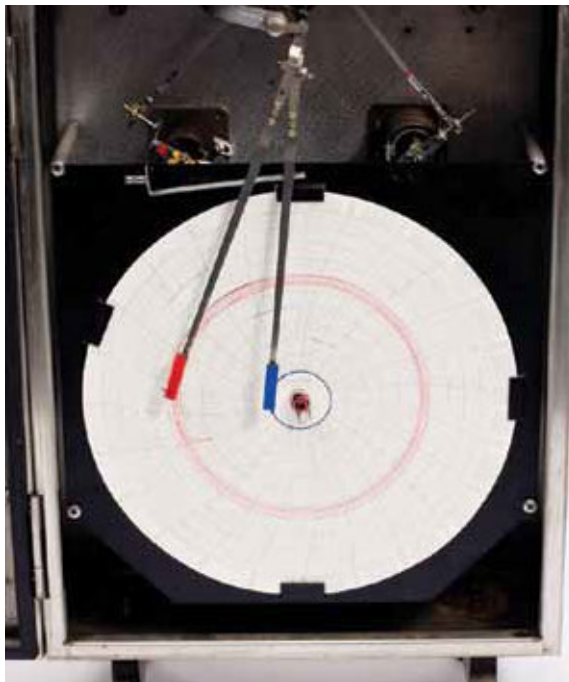

^ Typical chart recorder

A Master's Guide to Ship's Piping is jointly published for the Standard Club, by the Managers' London Agents in association with RINA.

Charles Taylor & Co. Limited

Standard House, 12–13 Essex Street,
London, WC2R 3AA, England

Registered in England No. 2561548

Telephone: +44 20 3320 8888
Fax: +44 20 3320 8800
Emergency mobile: +44 7932 113573
E-mail: p&i.london@ctcplc.com

Charles Taylor & Co. Limited is an appointed representative of Charles Taylor Services Limited, which is authorised and regulated by the UK Financial Services Authority.

Please send any comments to the editor –

Chris Spencer

E-mail: chris.spencer@ctcplc.com
Telephone: +44 20 3320 8807
Website: www.standard-club.com

The information and commentary herein are not intended to amount to legal or technical advice to any person in general or about a specific case. Every effort is made to make them accurate and up to date. However, no responsibility is assumed for their accuracy nor for the views or opinions expressed, nor for any consequence of or reliance on them. You are advised to seek specific legal or technical advice from your usual advisers about any specific matter.

Charles Taylor Consulting is a leading global provider of management and consultancy services to insurers and insureds across a wide spectrum of industries and activities.

CTC
CHARLES TAYLOR
CONSULTING

CTC
CHARLES TAYLOR
CONSULTING

WWW.STANDARD-CLUB.COM